

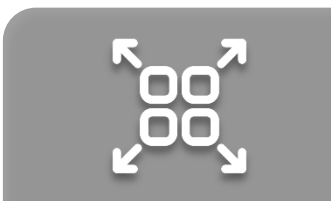

DECLUTCHABLE WORM GEARBOX USER MANUAL

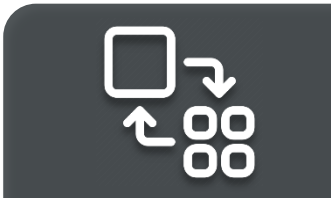
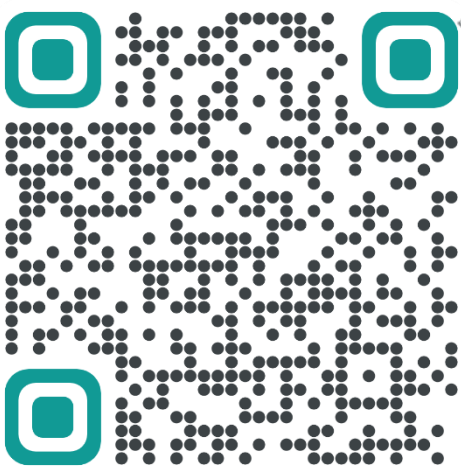

INTRODUCTION

Thank you for purchasing Convalve products. Each product has been thoroughly inspected after its production to offer you the highest quality and reliable performance. Please read the product manual carefully prior to installing and commissioning the product.

- Installation, commissioning, and maintenance of the product may only be performed by trained specialist personnel authorized by the plant operator accordingly.
- The manual should be provided to the end-user.
- The manual can be altered or revised without any prior notice. Any changes in the product's specification, design, and/or components may not be printed immediately until the following manual revision.
- The manual should not be duplicated or reproduced for any purpose without prior approval from Convalve.
- In case of any other problems that are not stated in this manual, please make immediate contact with Convalve for assistance.

TRANSPORTATION AND STORAGE

- Convalve recommends storing the Declutchable worm gearbox in a clean and dry environment. For optimal storage conditions, it is recommended to store the Declutchable worm gearbox, safeguarding them against adverse weather conditions and other potentially harmful elements. At Convalve, we prioritize the longevity and performance of our products, and these storage guidelines are meant to preserve the Declutchable worm gearbox' functionality and reliability throughout their lifecycle.
- Handling the Declutchable worm gearbox with care is of utmost importance to prevent any scratches, damage, or harm to the environment during transportation. Adequate protection should be provided to ensure the gearbox remains intact throughout the transportation process.

PRODUCT DESCRIPTION

Declutchable worm gear provides a means of manual control of valves, dampers, and other quarter-turn devices normally operated by air pressure. It is located between the valve and pneumatic actuator following an ISO5210, ISO5211 standard mounting system. This gear actuator has a female output drive connected to the internal gear mechanism. Turning the operating lever engages the worm gear, which in turn drives the internal gear mechanism.

The connection between the valve, gear actuator and actuator is a coupling shaft that rests on the valve stem. This shaft rotates through the output drive of the gear actuator and connects to the output drive of the actuator.

Designed with an IP65 rating, the Declutchable worm gear is dust and weather resistant. It works well in temperatures ranging from -20°C to 80°C.

CONSTRUCTION

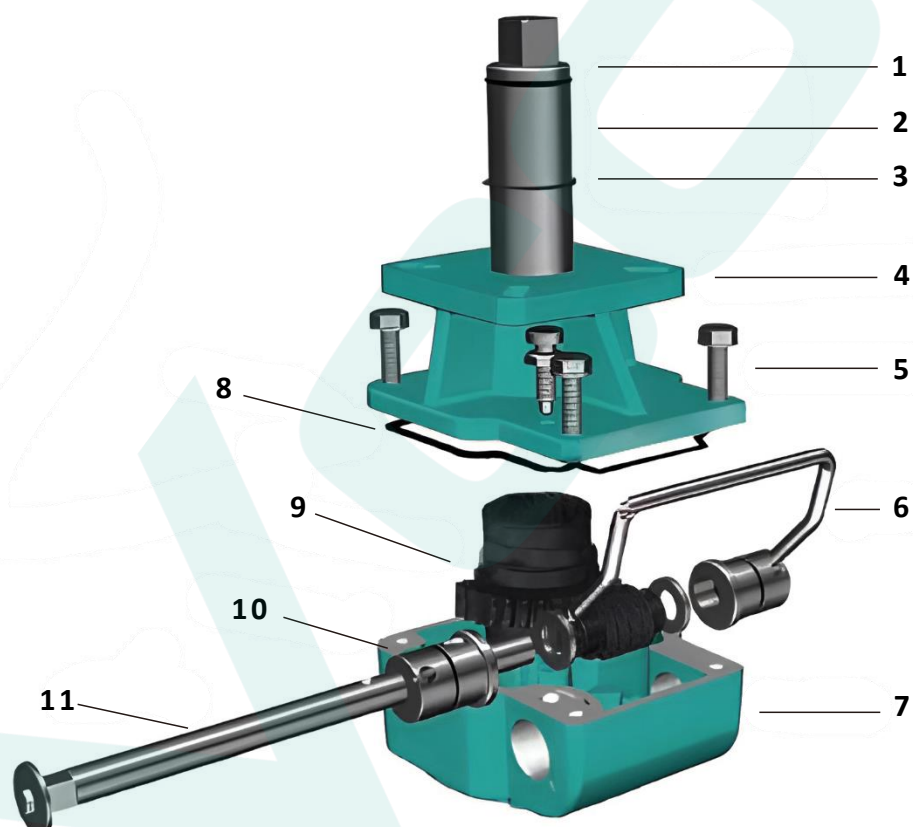

| NO | NAME | MATERIAL |
|----|-----------------|-----------------------|
| 1 | SHAFT | 45# Steel |
| 2 | SEAL RING | EPDM |
| 3 | SNAP SPRING | Spring Steel |
| 4 | UPPER END CAP | Aluminium Die Casting |
| 5 | SCREW | 304 |
| 6 | PULL ROD | 304 |
| 7 | BODY | Aluminium Die Casting |
| 8 | SEAL RING | EPDM |
| 9 | GEAR | EN-GJS-500 |
| 10 | REDUCING SLEEVE | EN-GJS-400 |
| 11 | WORM | EN-GJS-400 |

SPECIFICATIONS & RATINGS

1. The enclosure is designed with an IP65 weatherproof rating, ensuring protection against environmental elements.
2. The declutchable worm gearbox features ISO5210, ISO5211 standard mounting on both the top and bottom, facilitating easy integration.
3. It is suitable for an ambient temperature range of -20°C to +80°C as the standard.
 - For extremely cold environments, a low-temperature option allows operation down to -40°C.
 - Conversely, for high-temperature settings, a high-temperature option permits operation up to +120°C.

TORQUE SIZING GUIDELINES

1. To ensure optimal performance and longevity, it's recommended to size the declutchable worm gearbox at 5%-10% below their rated maximum output torque.
2. Consider the highest anticipated valve torque value during selection.
3. For applications involving spring return mechanisms, factor in the actuator spring torque alongside the valve torque. The declutchable worm gearbox must have the capability to overcome both the valve torque and the spring force.

INSTALLATION

1. Preparation

- Ensure that the valve, actuator, and declutchable worm gearbox are all in the same position, such as fully closed or fully open.
- Make sure that the mating surfaces are clean and free from any debris.
- Test the fitting of the mounting bolts/studs to confirm proper alignment.

2. Assembly to Valve

- Attach the declutchable worm gearbox to the valve using either 4 or 8 bolts/washer/studs, depending on the body's tapping. The declutchable worm gearbox is securely fastened.
- The female drive of the declutchable worm gearbox is designed to accommodate a male valve stem or coupling with slip-fit clearance.

General Recommendations for Valve Fasteners

- While both hex bolts and studs with nuts are acceptable, using studs and nuts is preferable as it facilitates easier alignment and assembly.
- It is highly recommended to use flat washers to ensure proper distribution of forces during installation.

3. Valve Shaft Orientation

The declutchable worm gearbox can be utilized in either a horizontal position or at a 45° angle from the vertical, depending on the requirements. Always adhere to the guidelines provided by the valve manufacturer for optimal usage.

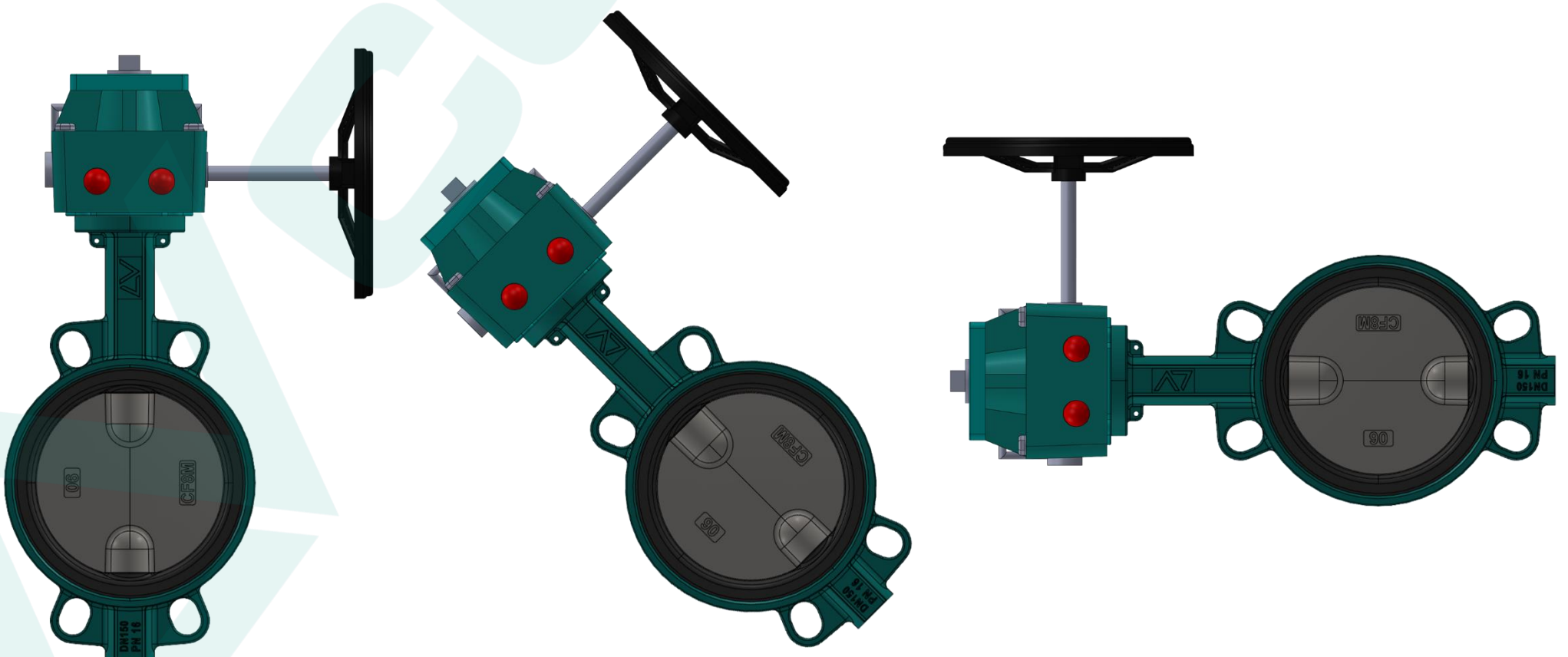
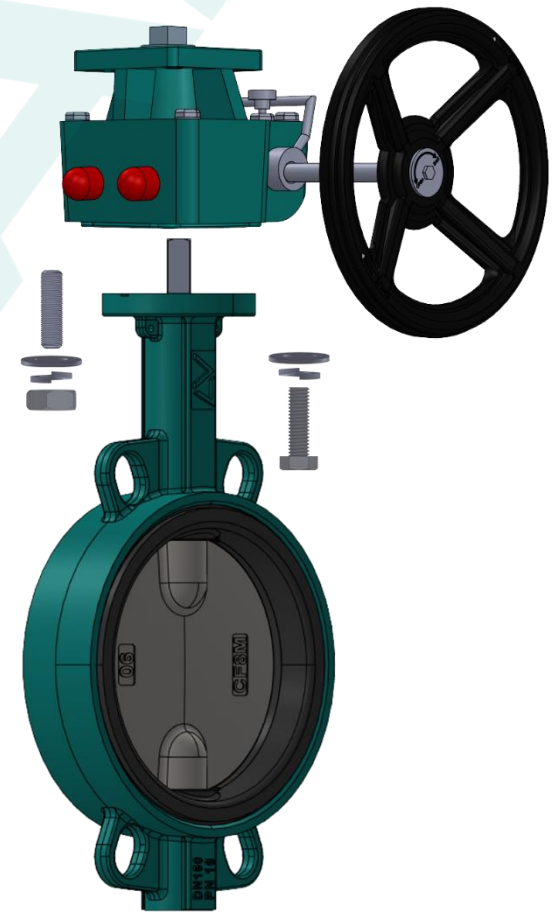

4. Handwheel Orientation vs. Valve:

It is advisable to position the handwheel shaft perpendicular to the pipeline to ensure sufficient operational clearance. In the case of parallel mounting, it is essential to conduct a test fitting of the handwheel to confirm appropriate clearance before securely fastening the mounting bolts.

- ① Preferred Shaft Orientation (Perpendicular)
- ② Alternate Shaft Orientation (Parallel, if clearance permits)

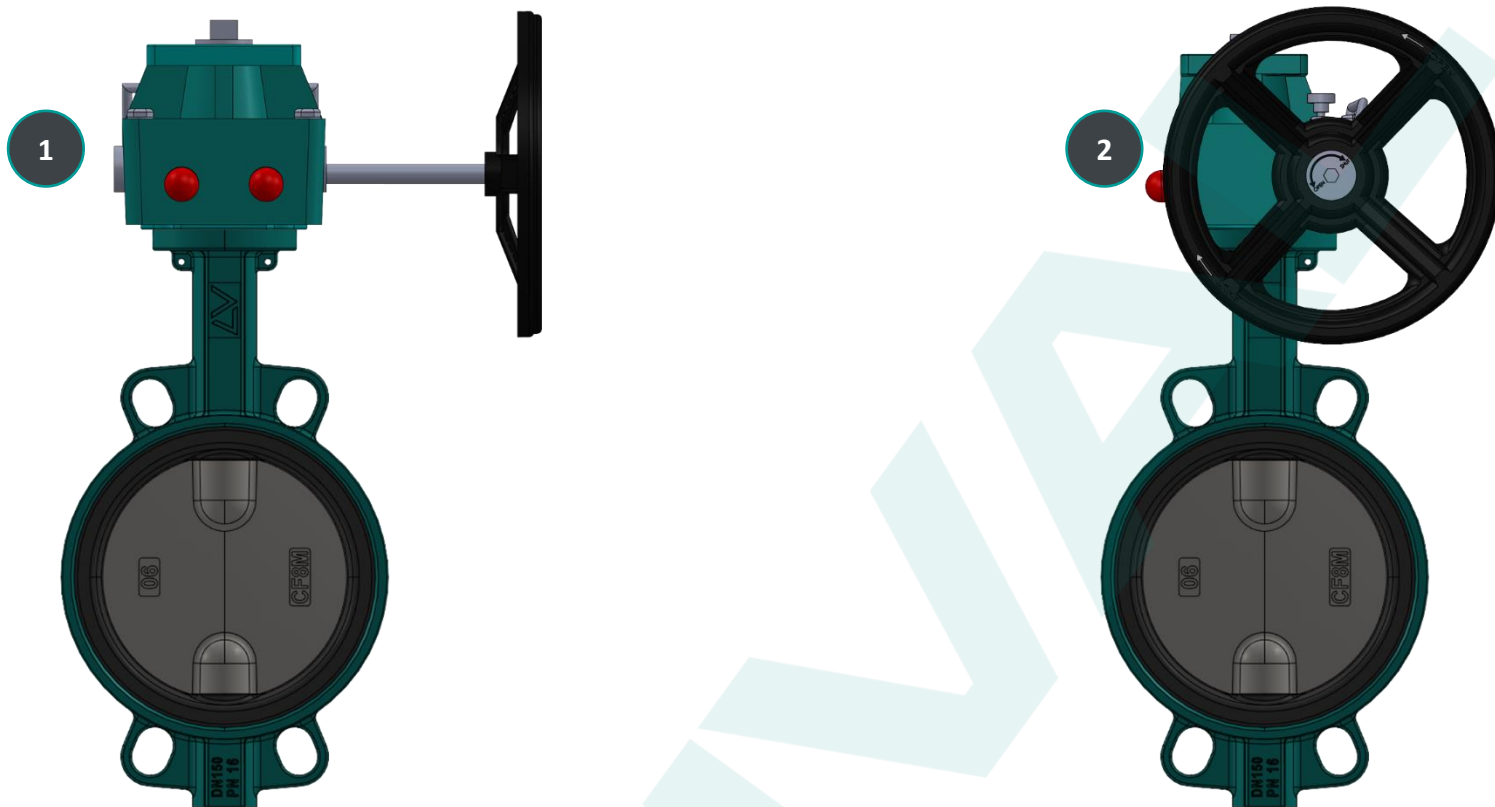

5. Assembly to Actuator

Secure the actuator to the declutchable worm gearbox using 4 bolts/washer/studs that pass through the body's holes. The declutchable worm gearbox features a male drive intended to be inserted into the female actuator drive with slip fit clearance.

General Recommendations for Actuator Fasteners

- While both hex bolts and studs with nuts are acceptable, using studs and nuts is preferable as it facilitates easier alignment and assembly.
- It is highly recommended to use flat washers to ensure proper distribution of forces during installation.

6. Handwheel Orientation in Relation to Actuator:

The recommended orientation involves aligning the longest dimension of the actuator perpendicular to the handwheel shaft. This orientation ensures adequate clearance. Confirm that the actuator's air ports face away from the handwheel.

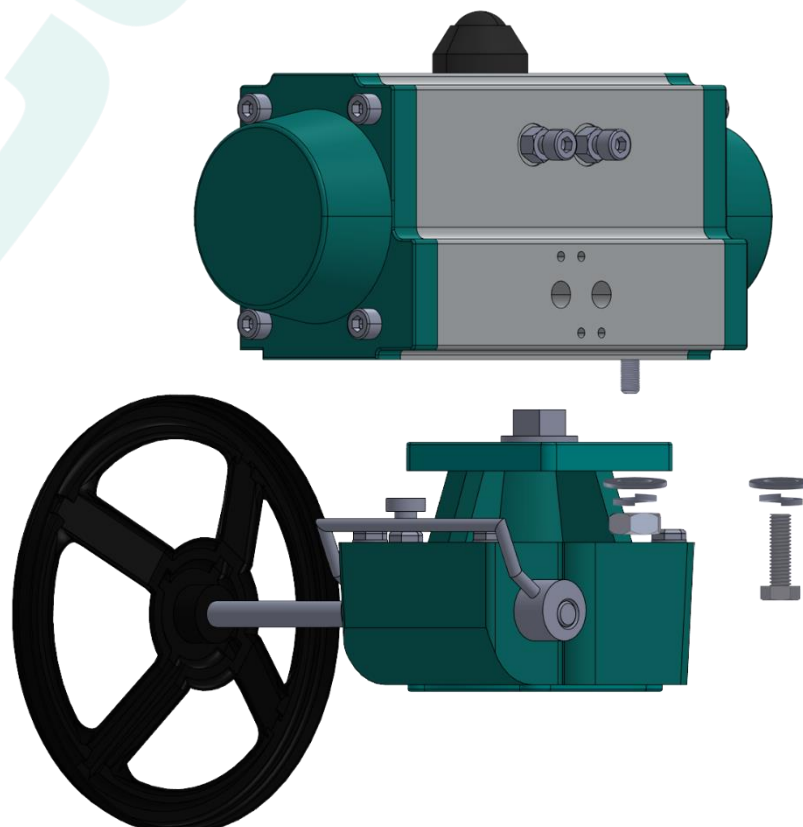

INSTALLATION

7. Travel Stops Adjustment:

To establish the fully open and closed positions of the valve, utilize the stops provided by the declutchable worm gearbox. Ensure that the actuator travel stops are loosened to their maximum extent. However, refrain from using actuator travel stops as position stops when a declutch declutchable worm gearbox is in place. Otherwise, excessive manual override forces might transmit to the actuator, leading to potential damage.

The valve's final stopping positions are managed independently by two travel stops. The left stop defines the open position (full counterclockwise rotation), while the right stop dictates the close position (full clockwise rotation).

For instance, if the valve isn't closing completely, increasing the rotation in the closed direction is required (to enhance closure). Loosen the nut of the CLOSE travel stop (located on the right) and turn it counterclockwise. Manually operate the valve to evaluate the newly adjusted closed position. Once the desired position is achieved, secure the travel stop nut to lock it in place.

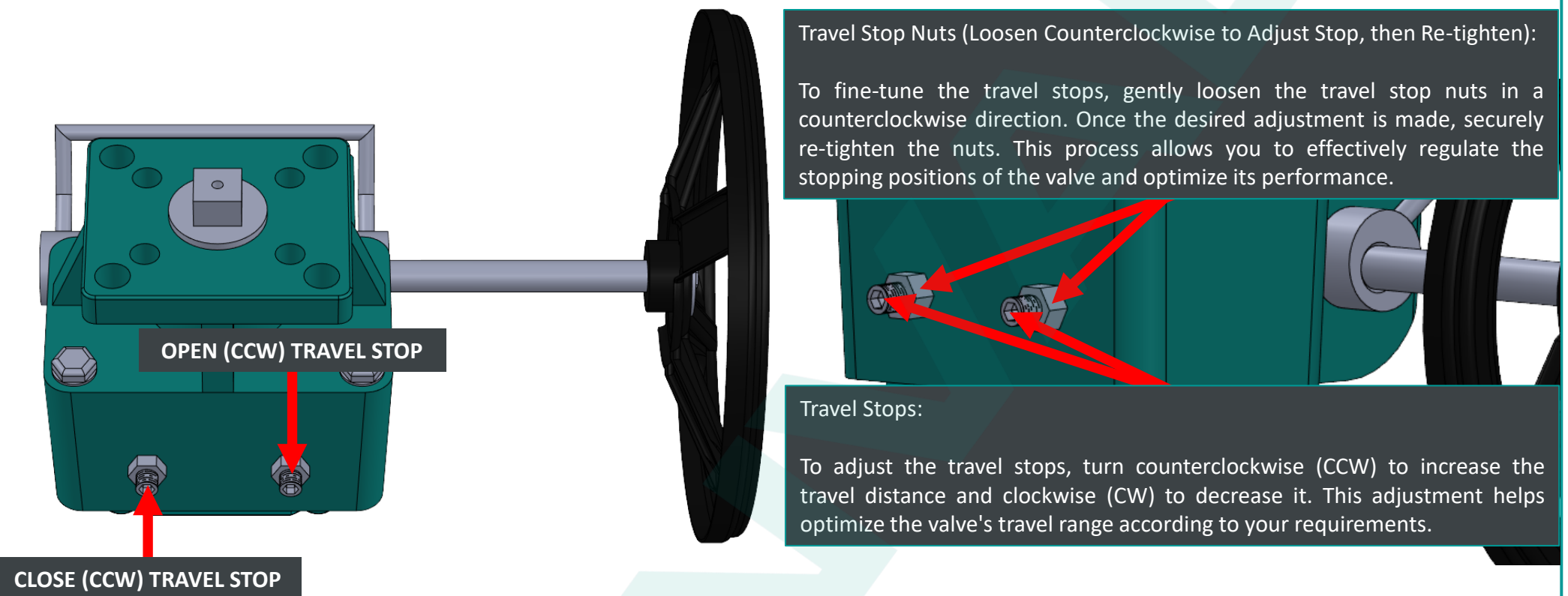

OPERATION

1. Valve / Actuator / Declutchable worm gearbox engagement:

When these components are assembled, the valve, actuator, and segment gear are consistently and permanently engaged. The clutch does not function to disconnect the actuator from the valve.

2. Clutch Lever Mechanism:

The clutch lever engages or disengages the worm gear from the segment gear, enabling free rotation of the segment gear. The gear operator's travel stops restrict the travel of the segment gear, which in turn restricts the overall rotation of the actuator/valve assembly.

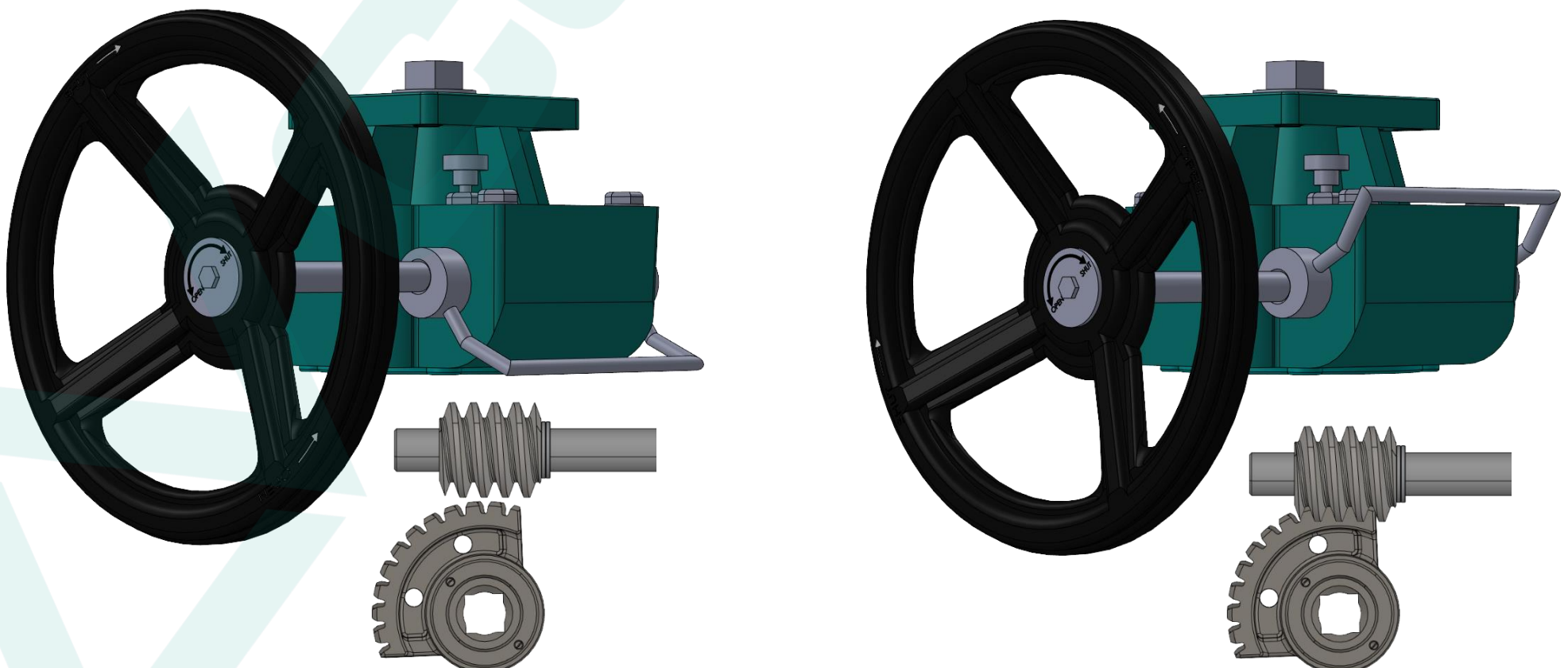

OPERATION

3. Recommended Use of Block and Bleed Device:

To release actuator air pressure during manual operation, it is advisable to employ a block and bleed device. If an integrated block & bleed valve is utilized, this process occurs automatically upon engaging the clutch.

4. Manual Operation (Lever UP)

Engage the clutch to operate the valve using the handwheel.

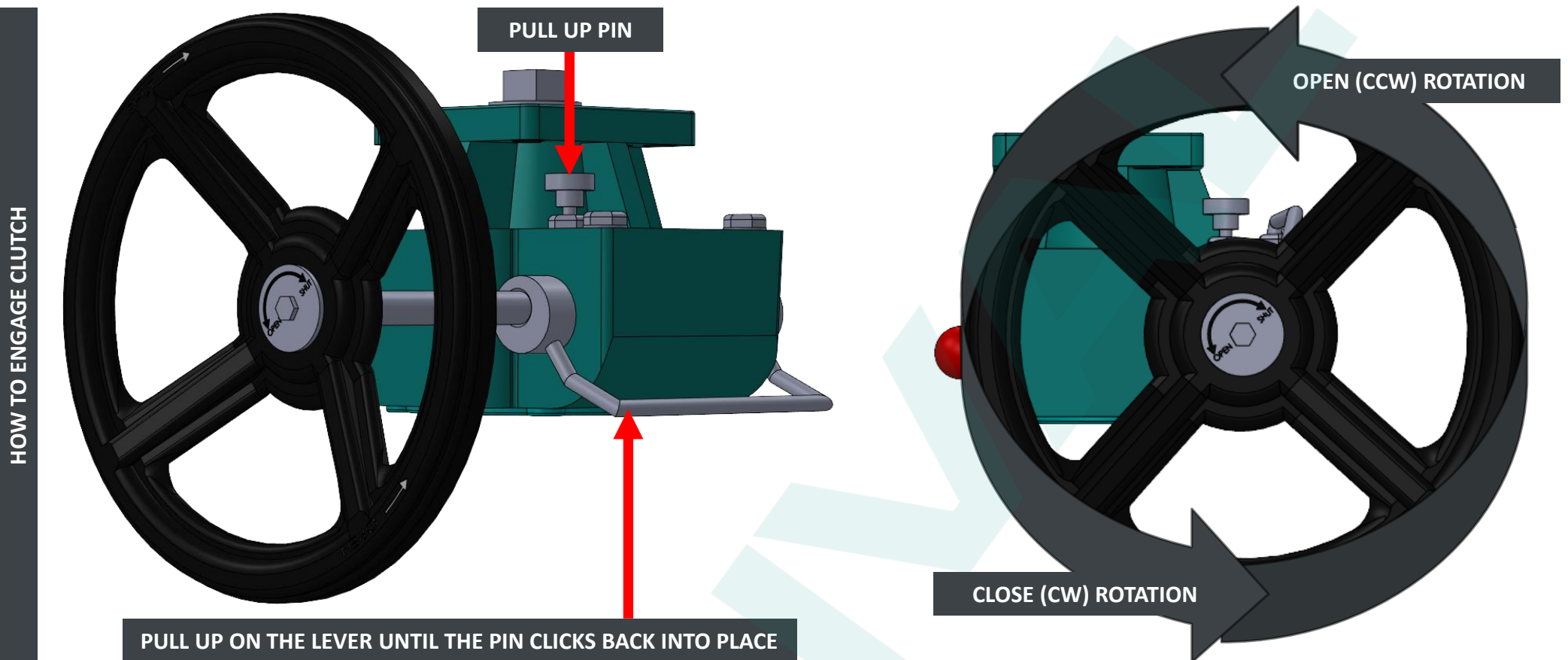

5. Automated Operation (Lever DOWN)

Always make sure to disengage the clutch when manual operation is not required. This allows the actuator to function properly in opening and closing the valve.

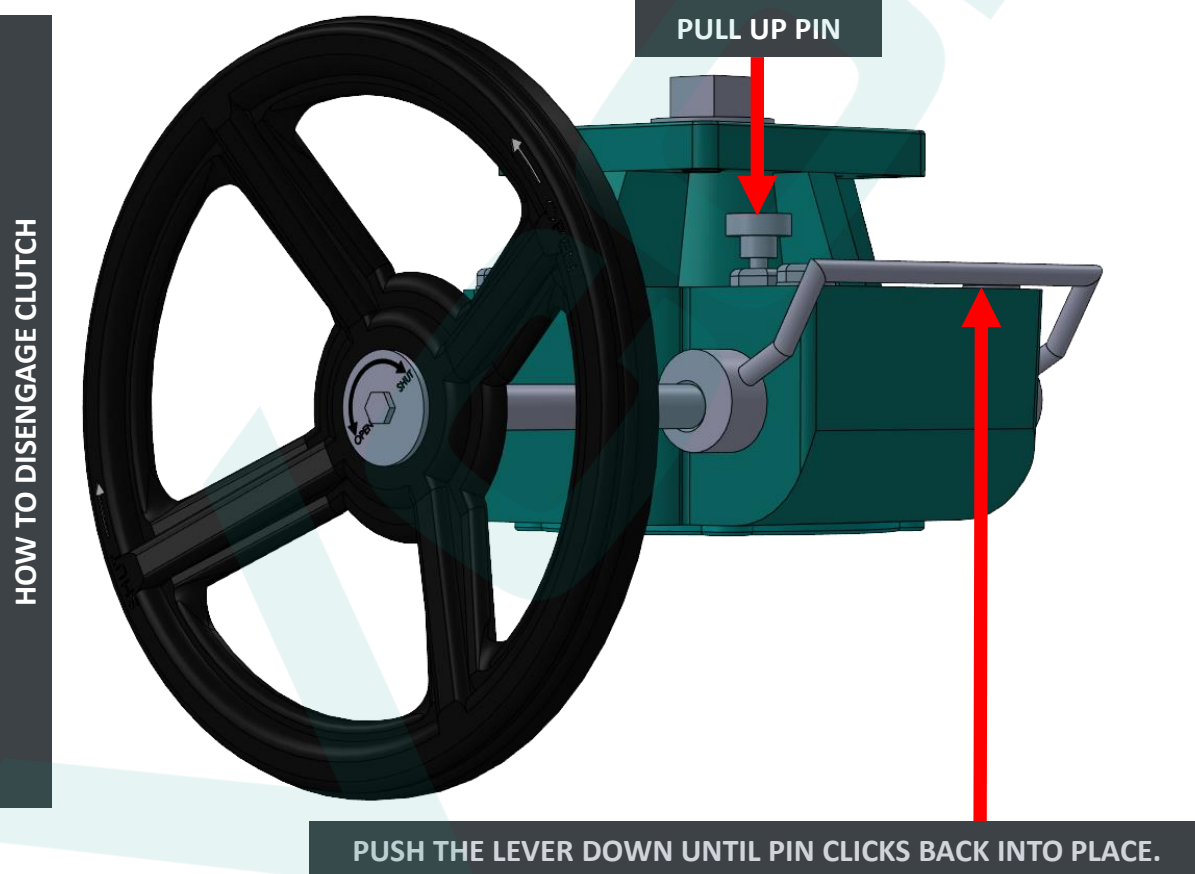

WHEN USING SPRING RETURN ACTUATORS, IT IS CRUCIAL TO ENSURE THAT THE ACTUATOR IS RETURNED TO ITS RELAXED SPRING POSITION BEFORE DISENGAGING THE CLUTCH. THIS PRECAUTION HELPS MAINTAIN PROPER FUNCTIONALITY AND PREVENTS ANY POTENTIAL ISSUES.

SAFETY

1. **Auto Mode Safety** : Always ensure that the clutch is disengaged when not manually operating the valve. Failure to do so may prevent the actuator from effectively opening or closing the valve.
2. **Manual Mode Safety** : Avoid applying excessive force to the handwheel and refrain from using additional tools for leverage, as this could lead to equipment damage or injury. If encountering excessive resistance, consult the troubleshooting section.
3. **Block & Bleed Recommended** : To prevent damage to the actuator, it is advisable to use a block and bleed device and/or deactivate electrical power to the actuator during manual operation.

MAINTENANCE

1. **Recommendation** : The declutchable worm gearbox arrives from the factory already pre-lubricated, and its internal gearing and bearings are sealed within an enclosure rated at IP65. This design eliminates the need for regular lubrication or maintenance.
2. **Removal** : Before removing the declutchable worm gearbox, ensure that the air supply and/or power to the actuator is disconnected. Safely remove the actuator first, and then proceed to remove the gearbox while ensuring that the valve is in a secure position suitable for maintenance.
3. **Repair** : If you require repairs or need to check whether the parts are under warranty, please get in touch with Convalve. The factory might request the return of parts for inspection and potential repair

TROUBLESHOOTING

GEARBOX HANDWHEEL WON'T MOVE

CAUSE : Valve, actuator, and declutchable worm gearbox not functioning in the same quadrant.
SOLUTION : Verify that all components are assembled in a consistent position, such as all being closed or all being open.

CAUSE : Inadequate engagement between the segment gear and worm gear.
SOLUTION : While engaging the clutch, gently move the handwheel back and forth to ensure proper engagement.

CAUSE : Declutchable worm gearbox is undersized and lacks sufficient torque.
SOLUTION : Compare the torque of the gear with the torque required by the valve. Make sure the gear is appropriately sized for the application.

GEARBOX EXTREMELY DIFFICULT TO OPEN OR CLOSE

CAUSE : Actuator remains pressurized.
SOLUTION : Release the air supply from the actuator by utilizing a block and bleed device.

CAUSE : Declutchable worm gearbox is undersized and lacks sufficient torque.
SOLUTION : Compare the torque capacity of the gear with the required torque of the valve. Verify that the gear is appropriately sized for the application.

ACTUATOR WON'T MOVE

CAUSE : Clutch is currently engaged.
SOLUTION : Disengage the clutch to allow for proper operation.

CAUSE : Valve, actuator, and declutchable worm gearbox are not operating in the same quadrant.
SOLUTION : Ensure that all components are correctly assembled in the same position, whether fully closed or fully open. Double-check the alignment to resolve the issue.

GEARBOX OR ACTUATOR WON'T OPEN OR CLOSE ALL THE WAY

CAUSE : Declutchable worm gearbox or actuator travel stops need adjustment.
SOLUTION : Adjust actuator travel stops out all the way and use gear operator stops to set full open/close positions.

CLUTCH WON'T DISENGAGE

CAUSE : Spring return actuator springs are currently compressed.
SOLUTION : Prior to disengaging, ensure that the actuator springs are returned to their relaxed state.