

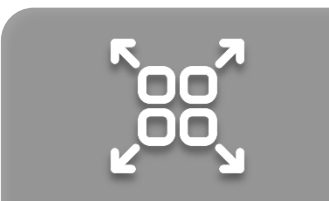

DIRECT MOUNT SOLENOID VALVE USER MANUAL

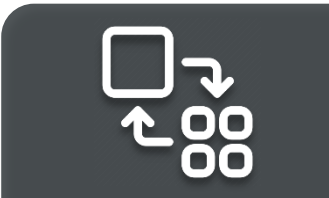
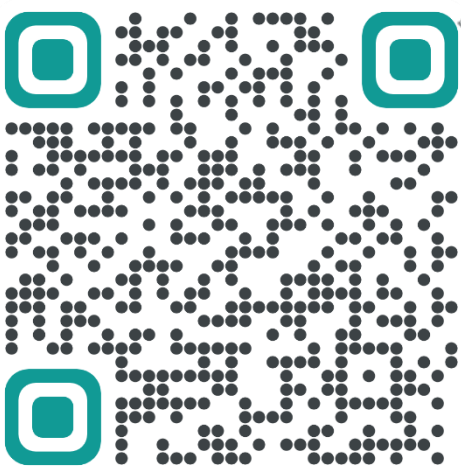

INTRODUCTION

Thank you for purchasing Convalve products. Each product has been thoroughly inspected after its production to offer you the highest quality and reliable performance. Please read the product manual carefully prior to installing and commissioning the product.

- Installation, commissioning, and maintenance of the product may only be performed by trained specialist personnel who have been authorized by the plant operator accordingly.
- The manual should be provided to the end-user.
- The manual can be altered or revised without any prior notice. Any changes in product's specification, design, and/or any components may not be printed immediately but until the following revision of the manual.
- The manual should not be duplicated or reproduced for any purpose without prior approval from Convalve.
- In case of any other problems that are not stated in this manual, please make immediate contact with Convalve for assistance.

TRANSPORTATION AND STORAGE

- Convalve recommends storing direct mount air solenoid valves in a clean and dry environment. For optimal storage conditions, it is recommended to store the direct mount air solenoid valves indoors, safeguarding them against adverse weather conditions and other potentially harmful elements. At Convalve, we prioritize the longevity and performance of our products, and these storage guidelines are meant to preserve the direct mount air solenoid valve's functionality and reliability throughout their lifecycle.
- Handling the direct mount air solenoid valves with care is of utmost importance to prevent any scratches, damage, or harm to the environment during transportation. Adequate protection should be provided to ensure the direct mount air solenoid valves remains intact throughout the transportation process.

DESCRIPTION

The Convalve direct mount air solenoid valves can be easily adapted for 5/2 or 3/2 NC functions to electrically control double-acting or spring-return air actuators. Their compact high-flow design features a black anodized aluminum body with a low-wattage molded coil. The valve's unique long-life spool and sleeve design allows it to be used with both lubricated and non-lubricated compressed air.

For added convenience, the twist and lock manual override feature enables easy operation of the valve during setup, testing, or power outage situations. Each valve includes an easy-to-wire 1/2" conduit DIN plug connector with screw terminals, simplifying the wiring process.

Moreover, the valve offers excellent environmental protection, safeguarding against the ingress of liquids, dust, and other foreign matter. This feature ensures the valve's durability and reliability even in challenging operating conditions.

MOUNTING

To mount the direct mount solenoid valve to the side of pneumatic actuators with the international standard Namur VDI/VDE 3845 interface, follow these steps using the (2) M5x35mm socket head cap screws (included):

For Double Acting (DA) Actuators :

1. Bolt the valve to the side of the actuator using the provided screws.
2. This valve will operate as a 5-way function.

For Spring Return (SR) Actuators :

1. Bolt the valve to the side of the actuator using the provided screws.
2. This valve will operate as a 3-way normally closed function.

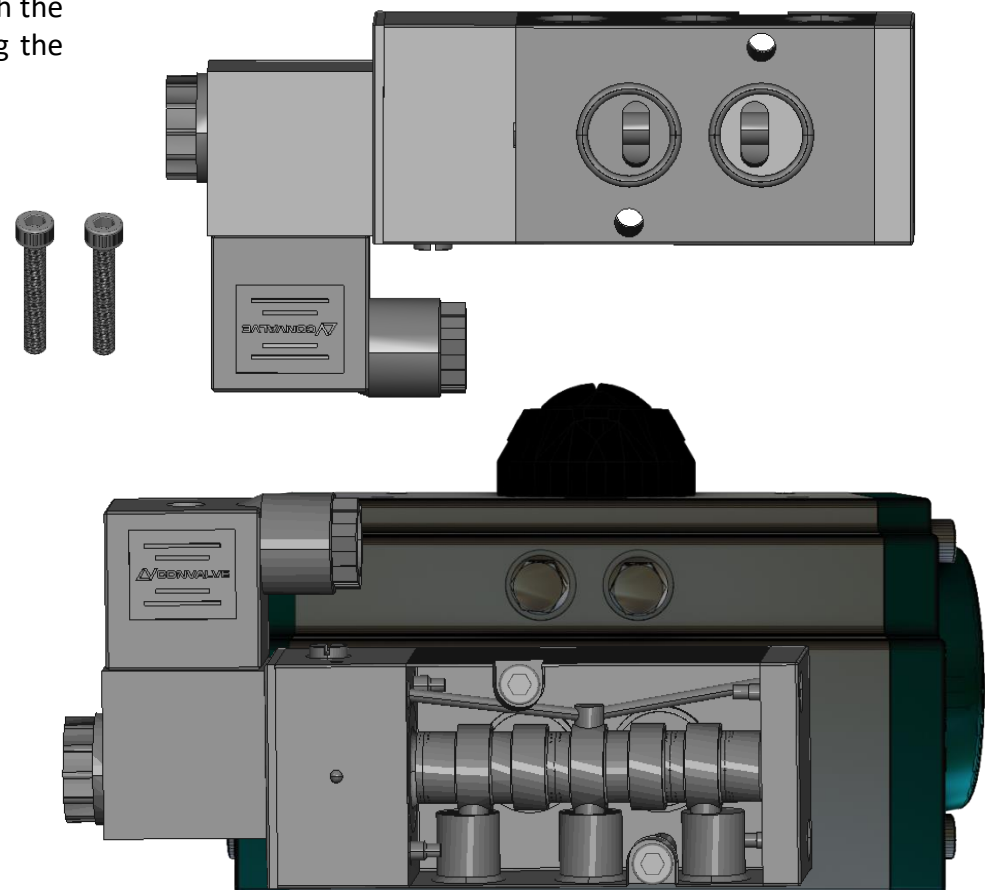

PILOT AIR SUPPLY

The air supply to the solenoid valve should be filtered to a level below 40 microns and can consist of either dry or lubricated compressed air. The pressure rating for the solenoid valve is between 2-8 bar. In most cases, Convalve air-actuated valve assemblies require a pressure of 5.5-8 bar for proper operation.

Additionally, it is essential to ensure that the air supplied is moisture-free, especially if the temperature falls below 0° C (32° F) to prevent freezing and potential operational issues. Keeping the air supply clean, dry, and within the specified pressure range ensures the reliable and efficient performance of the solenoid valve and the associated air-actuated valve assemblies.

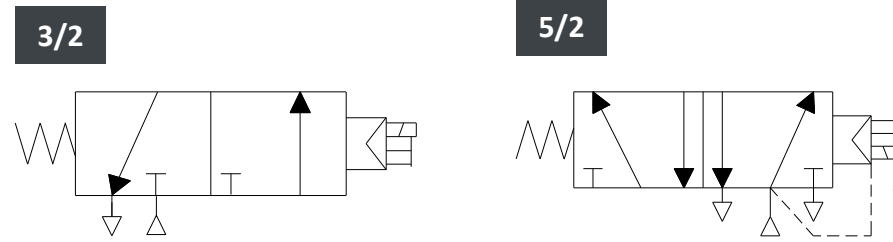

PILOT AIR CONNECTION

1. Identify the 1/4 BSP center port, designated as port number 1. This port will be connected to the air supply.
2. Connect a hose or tubing to the 1/4 BSP center port. Ensure that the hose or tubing is of the same size as the port.
3. Connect the other end of the hose or tubing to the air supply, which should be a source of compressed air.
4. Optionally, you can install mufflers or speed control mufflers in exhaust ports 3 and 5. This will prevent dirt and contamination from entering the valve.
5. Ensure that the exhaust ports are not plugged. It is vital to prevent pressure build-up that could damage the solenoid valve.

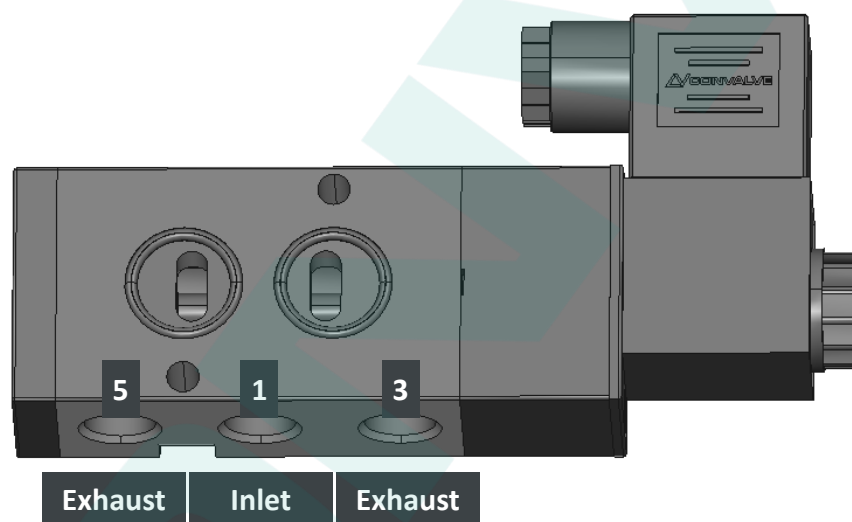

WIRING

1. Remove the retainer screw (2) from the connector.
2. Use a small screwdriver to carefully pry the terminal block out of the connector.
3. Confirm that the coil voltage is correct for the application.
4. Connect the power wires to PIN 1 and PIN 2 (note that polarity is not sensitive).
5. Connect the earth ground wire to the remaining flat PIN.
6. Reassemble the connector, ensuring that the connector gasket (1) is installed correctly.
7. Tighten the retainer screw (2) securely to complete the wiring process.

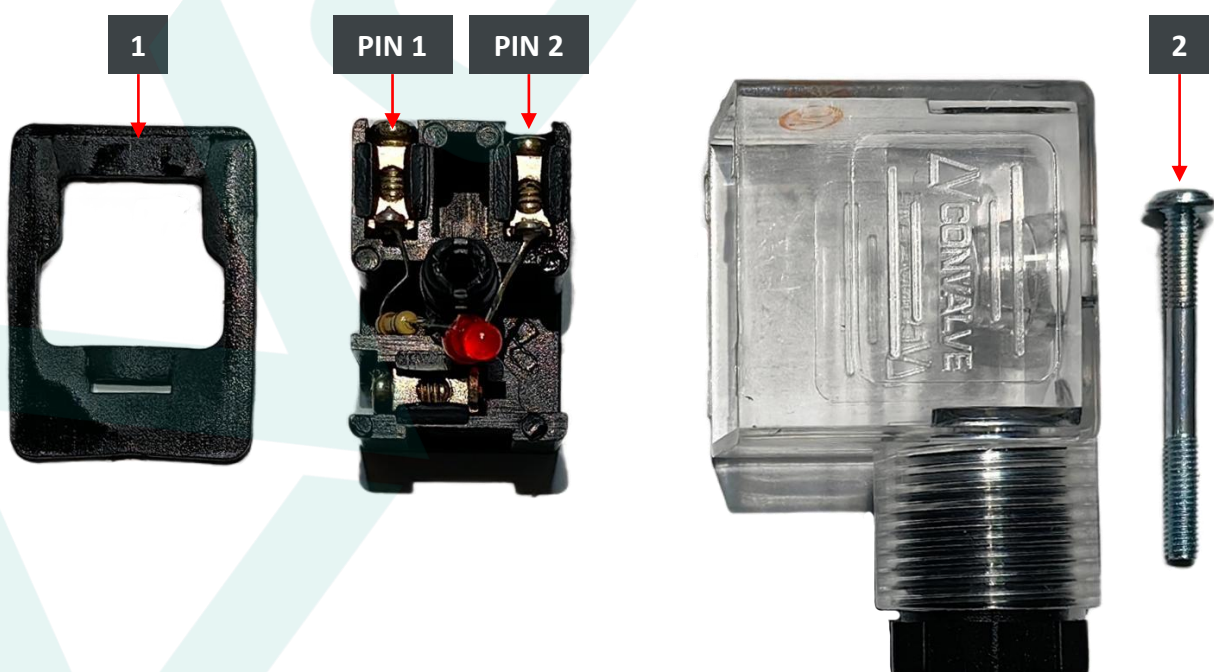

WARNING!

Before connecting power to the solenoid valve, it is crucial to check the coil markings to ensure that the correct voltage is being applied. Verify that the voltage matches the specifications required for the solenoid valve. Applying the wrong voltage can lead to improper operation or damage to the valve. Double-checking the coil markings will help ensure a safe and successful electrical connection.

OPERATION

When the solenoid valve is de-energized (power is turned off), the actuator will return to the closed position (off or position 1).

When the solenoid valve is energized (power is turned on), the actuator will move to the open position (on or position 2).

When using these solenoid valves with spring return (SR) actuators, the actuator will automatically fail to the closed position in the event of a loss of power or loss of air pressure (failsafe). This ensures a safe and reliable operation, as the actuator will automatically close in the event of any power or air supply interruption.

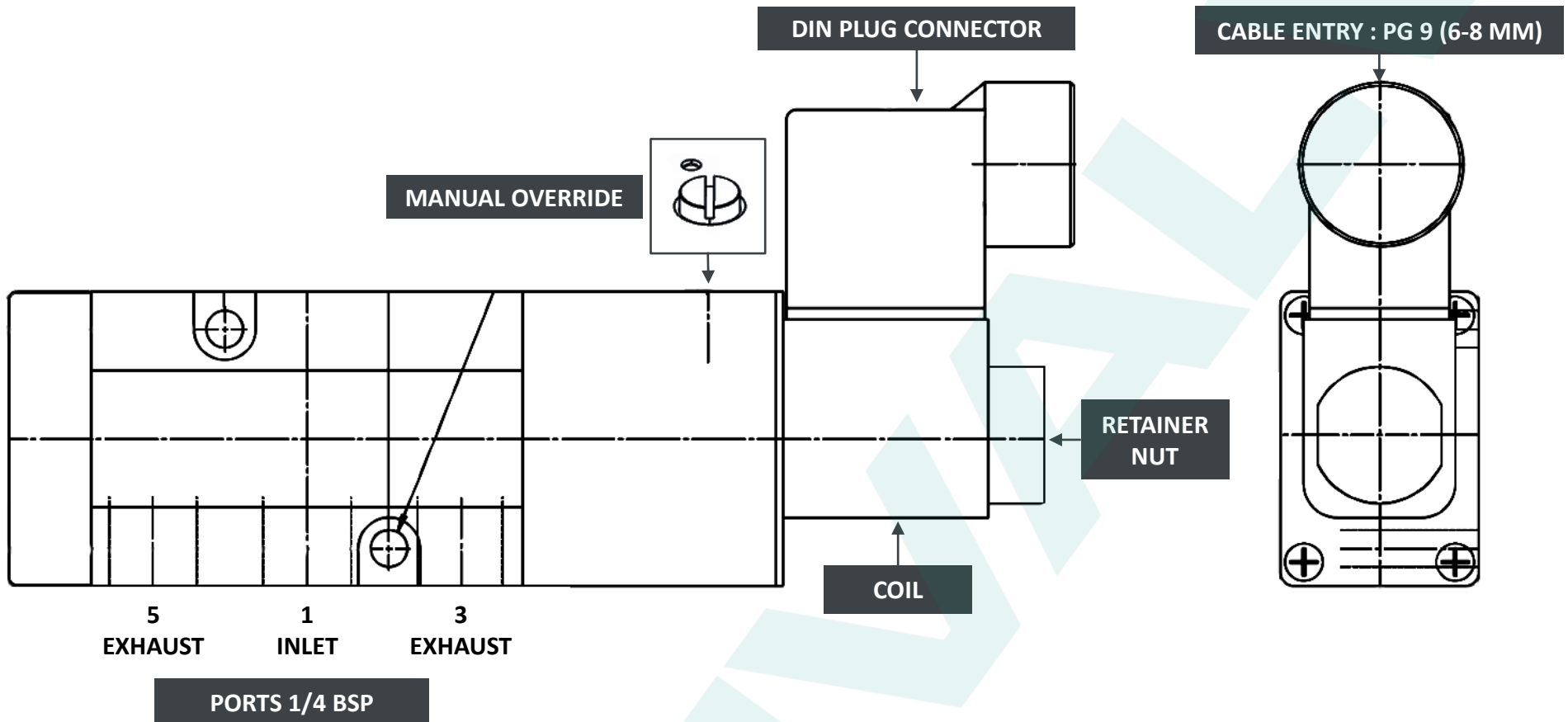

ENCLOSURE AND TEMPERATURE RATING

The solenoid enclosure has an IP65 rating, making it dust-tight and weatherproof. This means it is well protected against the ingress of dust and can withstand various weather conditions.

The media temperature range for the solenoid valve is from -25 to 80° C (-13 to 176° F). It can efficiently operate within this temperature range, ensuring its performance is not affected by varying media temperatures.

The ambient temperature range for the solenoid valve is from -20 to 50° C (-4 to 122° F). This indicates that the valve can function effectively within this range of ambient temperatures, providing reliable operation even in different environmental conditions.

DUTY CYCLE

The solenoid valve coil is designed and rated for 100% continuous duty service. This means that the coil can operate continuously without any duty cycle limitations or the need for rest periods. It is capable of sustaining its performance and functionality under continuous electrical energization, ensuring reliable and uninterrupted operation for extended periods without overheating or damage.

MANUAL OVERRIDE

The solenoid valve is equipped with a manual override feature, allowing it to be operated manually for setup, testing, and situations where electrical power is not available. The manual override is designed as a twist and hold mechanism.

1. To operate the manual override:

- Turn the slot head screw clockwise until it reaches the '1' position. This will engage the manual override mode.
- The valve can now be manually operated or positioned as needed.
- To return to normal electrical operation, turn the slot head screw counterclockwise to the '0' position.
- By using the manual override, you can ensure smooth and precise control of the valve when required, even in situations where electrical power is not accessible.

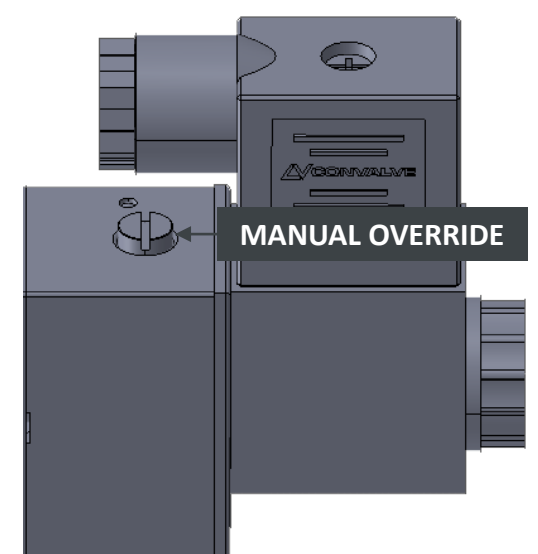

WARNING!

- To operate the valve electrically, the manual override must be in the position (shown).
- Before performing any service work, turn off the power and air pressure.



MAINTENANCE

- The valves are designed to be maintenance-free, with the exception of coil replacement.
- No other parts require regular maintenance.
- Cleaning the valve is possible with warm soapy water, but avoid using solvents for cleaning.
- It is recommended to cycle the valve at least once per month to ensure proper operation.

Coil Replacement :

- Before starting any service work, disconnect the electrical power by unplugging the DIN plug connector.
- Remove the coil retainer nut and carefully slide the coil off the core tube.
- Install the new coil, then replace and securely fasten the retainer nut.
- Reconnect the DIN plug connector to complete the coil replacement process.

NOTES :

- When cleaning the valve, be sure to avoid getting any water or soap inside the coil.
- If the valve is exposed to harsh environments, it may be necessary to clean it more frequently.
- If the valve is not functioning properly, it may be necessary to replace the coil.