

FLOW METER



CREATIVE • INNOVATION • PROCESS



SKU:1587



Scan me

FLOW METER VARIABLE AREA FLOW METER

Description

CVAF series flowmeters operates according to the proven variable area principle. The float gets lifted by the flowing medium and indicates the flow with its upper edge on the scale attached to the device. If floats with integrated magnets are used, optionally, alarm contacts or a measuring transmitter can be attached to the device. All devices possess a male thread on the measuring tube and are additionally equipped with standard PVC adhesive sleeves. As an option, also female threaded fittings made of PVC, PP, ABS or stainless steel can be supplied.

Advantages

Polysufone (PSU) or Pc body, Fittings made of PVC ABS or SS Floats Capable of withstanding higher temperatures Thread joint and panel-mounted fittings are easy to install, economical and durable

- Unbreakable and corrosion resistant
- Radially extendable
- Special self-adhesive scales for liquid and gaseous media
- Check rail for accessories (limit switches)
- Various number of nominal sizes available

Application

Due to a wide variety of materials and easily interchangeable measurement scales, the CVAF series plastic flowmeters can be suitable for most of media including aggressive media.

The main areas of application are water treatment, effluent technology, chemical and food-processing industries and many others.

Operation

Variable area flow meters are used in pipelines and determine the volume flow of liquids or gases there. The flow meter consists of a conical measuring tube with a float inside it.

The measuring principle is based on the body being vertically deflected through the flowing medium. Various forces act on the float - the flow resistance, the buoyant force, as well as the weight force of the body.

In summary, if the volume flow rises, the float is lifted. The current flow is indicated on the scale at the top of the float.

These flow meters feature a water scale in l/h standard. Optional air scales are also available for various operating pressures. Two adjustable reference value indicators facilitate monitoring of the rate of flow. Limit contacts are available as accessories.

Materials

Measuring tube	Transparent, with heavily reduced humidity absorption Polysulfon; transparent PVDF; opaque (yellowish-white)
Float	PVDF, optional PVDF with integrated magnet
Seals	FPM
Tube connections	PVC, optional PP or ABS, stainless steel

Dimension

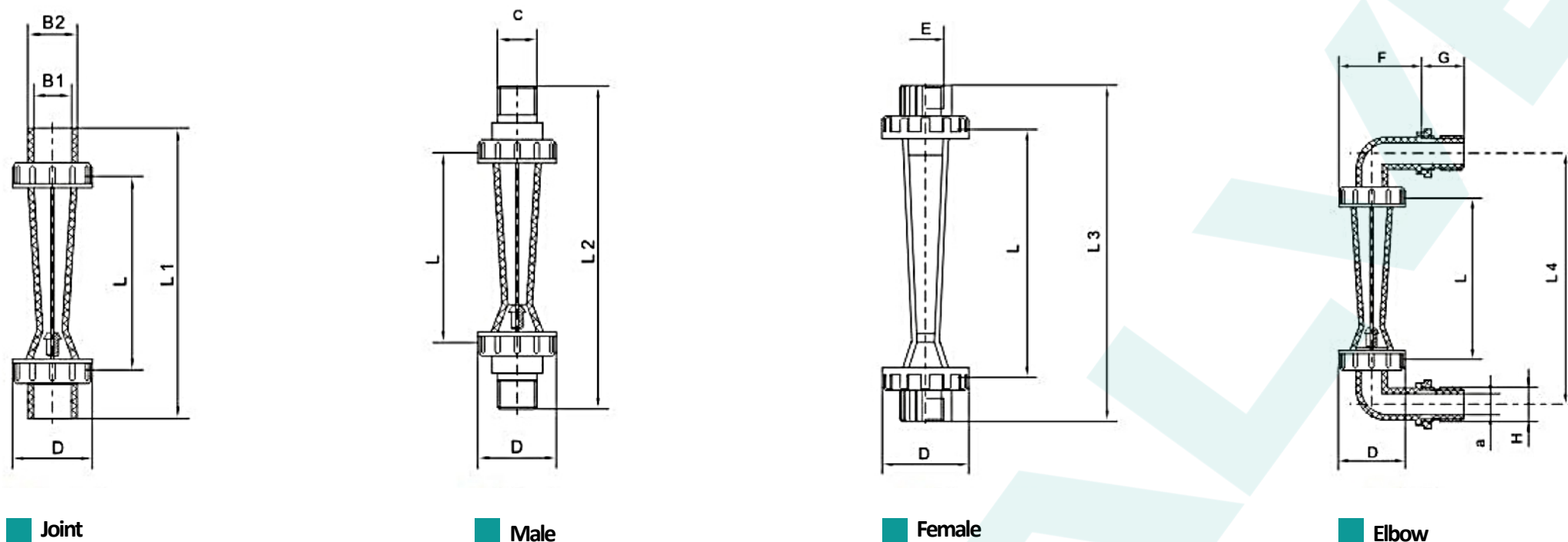

DATASHEET

RANGE							
MODEL	DN	GPM	LPM	m ² /h	ACCURACY	TEMP °C	PRESSURE
CVAF-15	15	0,1-1	0,5-4	10-100l/h	4%	0-60	< 10 Bar
		0,2-2	1-7	16-160l/h		0-100	
		0,5-5	1,8-18	25-250l/h		0-60	
CVAF-15	15	0,1-1	0,5-4	40-400l/h		0-100	
		0,2-2	1-7	50-500l/h		0-60	
		0,5-5	1,8-18	60-600l/h		0-100	
CVAF-25	25	0,8-8	3-30	100-1000l/h		0-60	
		1-10	4-40	0,25-2,5 0,16-1,6 0,1-1		0-100	
CVAF-32	32	1,2-12	5-50	0,4-4		0-60	
		2,20	8-80	0,6-6		0-100	
		2,5-25	10-100	0-60			
CVAF-50	50	2,5-25	10-100	0,4-4		0-100	
		5-45	20-180	0,6-6	0-60		
		7-70	25-250	1-10 1,6-16	0-100		
CVAF65	65	25-110	80-400	5-25	0-60		
		40-160	150-650	8-40	0-100		
		50-250	200-1000	12-60	0-100		

DIMENSION FOR INSTALATION

MODEL	L	D	L1	B1	B2	L2	C	L3	E	L4	P	G	A	H
CVAF-15	100	Φ42	150	Φ20	Φ26	170	1/2" BSP 1/2" NPT			155	52	27	Φ13	1/2" BSP 1/2" NPT
CVAF-15	160	Φ50	210	Φ20	Φ26	225	1/2" BSP 1/2" NPT	210	1/2" BSP 1/2" NPT	220	56	27	Φ13	1/2" BSP 1/2" NPT
CVAF-25	170	Φ59	230	Φ32	Φ39	250	3/4"NPT	225	3/4" BSP 3/4" NPT	270	70,5	28	Φ20	3/4" BSP 3/4" NPT
CVAF-32	225	Φ72	290	Φ40	Φ49	310	1"NPT	290	1" BSP 1" NPT	345	86	35	Φ26	1" BSP 1" NPT
CVAF-50	290	Φ98	375	Φ63	Φ73	400	2"NPT	370	2"NPT	440	109	40	Φ45	2" BSP 2" NPT
CVAF-65	325	Φ120	420	Φ75	Φ89	445								

Technical Parameters of CVAF Series Flow Meter (Flange Connection)

Model	Diameter (DN)mm	Range		Accuracy	Conditions		Size (mm)								Suit pipe DN(mm)			
		Long Tube Type	Short Tube Type		°C Temperature	Mpa Pressure	Long Tube Type				Short Tube Type							
							L	D1	D2	D3	L	D1	D2	D3				
CVAF-15	15	10-1 00l/h 16-1601/h 25-2501/h 40-4001/h 60-6001/h	5-50l/h 10-1001/h 16-160l/h 25-250l/h 40-400l/h 60-600l/h 100-1000l/h	±4%	0-60	^0.6	320	14	65	95	241	14	65	95	15			
	470																	
CVAF-20	15									320	14	75	105	241	14	75	105	20
	470																	
CVAF-25	25	100-1000l/h 160-16001/h 250-25001/h	100-1000l/h 160-16001/h 250-25001/h							432	16	85	115	281	16	85	115	25
	470																	
CVAF-32	32		0.4-4m ³ /h 0.6-6m ³ /h											355	17	100	140	
CVAF-40	40	0.4-4m ³ /h (with leader) 0.6-6m ³ /h (with leader) 1-10m ³ /h (with leader)								570	18	110	150	500	18	110	150	40
CVAF-50	50	0.4-4m ³ /h 0.6-6m ³ /h 1 -10m ³ /h 1.6-1 6m ³ /h	0.4-4m ³ /h 0.6-6m ³ /h 1 -10m ³ /h 1.6-1 6m ³ /h							520	18	125	165	430	18	125	165	50
	570																	
CVAF-65	65	with leader	2.5-16m ³ /h 5-25m ³ /h 8-40m ³ /h 12-60m ³ /h											530	18	145	185	65
CVAF-80	65		2.5-16m ³ /h 5-25m ³ /h 8-40m ³ /h 12-60m ³ /h											540	18	160	200	80
CVAF-100	100	14-90m ³ /h 18-120m ³ /h 20-150m ³ /h 25-180m ³ /h 25-200m ³ /h	14-90m ³ /h 18-120m ³ /h 20-150m ³ /h 25-180m ³ /h 25-200m ³ /h							550	18	180	215	510	18	180	215	100
	540																	
CVAF-125	125									550	18	210	250	510	18	210	250	125
CVAF-150	150						560	22	240	280	510	22	240	280	150			