

**TOP FLANGED BRASS BALL VALVE**



ISO 9001  
Quality 

ISO 14001  
Environment 

OHSAS 18001  
Health & Safety 



## TOP FLANGED BRASS BALL VALVE

Scan me

### DESCRIPTION

Energized PTFE ball seats are designed for low torque and extended cycle life. These ball valves incorporate a unique leak-free double Viton stem seal design. Actuator-ready design utilizes industry standard ISO5211 direct mounting pad.

### FEATURES

- CW617N brass body
- Full Port design for unrestricted flow
- Actuator ready ISO5211 direct mounting pad
- Industrial grade and designed for low operating torque
- Blow-out proof stem
- Energized PTFE ball seats for lower torque and longer life
- Leak-free double FKM stem seal packing
- Operating temperature : -10 ° C = 150 ° C
- Pressure class PN40

### APPLICATION

Brass full port ball valves are typically used for on-off control of water, air, oil, vacuum and other media compatible with the materials of construction. Valves can be manually operated or direct mounted to air or electric actuators using the standard ISO5211 mounting pad. This eliminates the need for extra mounting brackets and couplings. Suitable for vacuum service up to 736mmHg (29inHg)

### OPERATION

Turning the valve actuator one quarter-turn (90°) rotates the ball from close to the fully open position. Bare shaft design provides access to standard ISO5211 direct mounting flange

### OPTIONS

- Electric actuators
- Air Actuators
- Gearbox / Hand lever

**DIMENSIONS MM**

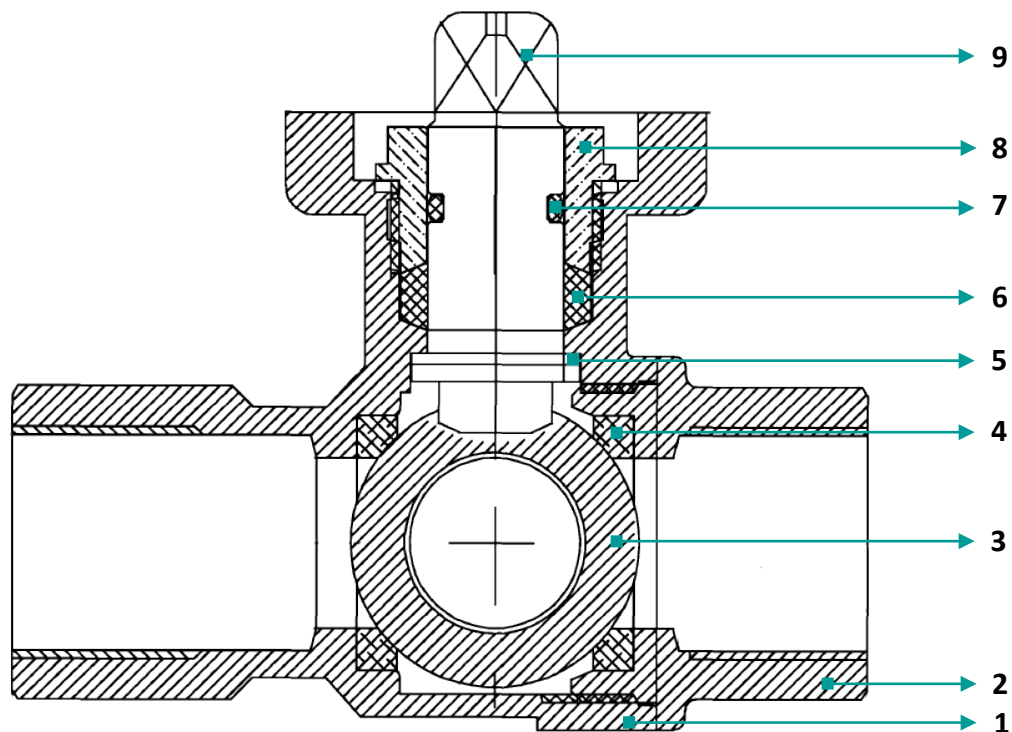

**STRUCTURE**

NO	PARTS NAME	MATERIAL
1	Body	Nickel Coated Brass
2	Body	Nickel Coated Brass
3	Ball	Stainless Steel
4	Seat	PTFE
5	Shaft Seat	PTFE
6	Shaft Seal	EPDM
7	O-ring	NBR
8	Nuts	Brass
9	Shaft	Brass

**(PTFE) PRESSURE-TEMPERATURE RATING**

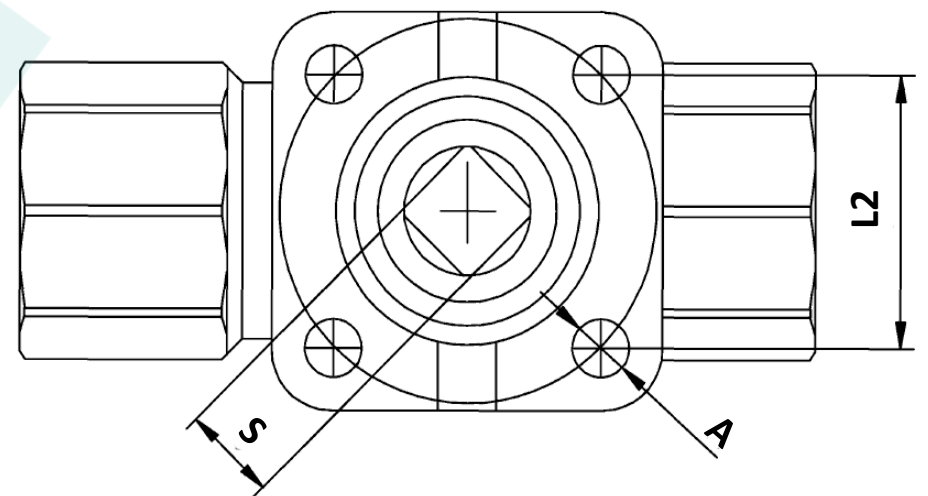
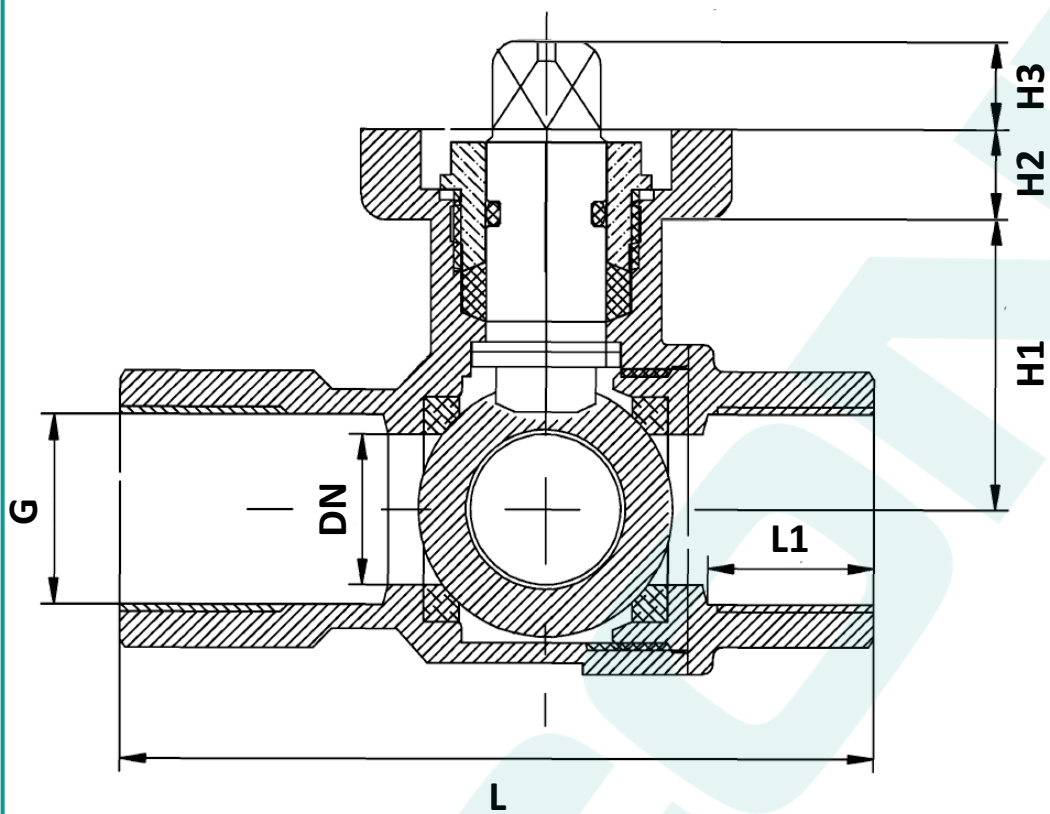
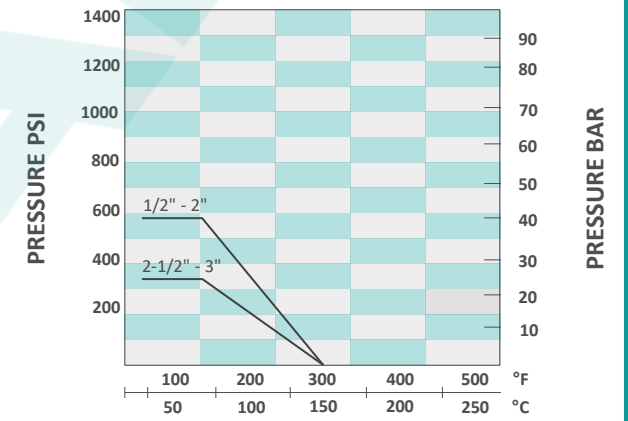

SIZE	1/2"	3/4"	1"	1 1/4"	1 1/2"	2"	2 1/2"	3"	4"
DN	15	20	25	32	40	50	65	80	100
L1	16,5	18,5	22	30	30	32	32	34	36
L2	25,4	25,4	25,4	30	35	35	35	49,5	49,5
A	5,5	5,5	5,5	5,5	6,7	6,7	6,7	9	9
L	75	80	90	112	117	139	160	180	210
H1	38	40	45	55	61	72,5	82,5	95	110
H2	9	10	9	10	10	13	10	12	12
H3	10	9,5	9,5	12	12	15	17	16	16
S	9	9	9	11	11	14	14	14	14
TORQUE (NM)	4	5,5	8	10	14	25	35	40	60
FLANGE SIZE	F03	F03	F03	F05	F05	F05	F07	F07	F07
WEIGHT (KG)	0.33	0.45	0.65	1.1	1.5	2.3	3.25	5.58	9.4